

Screw-in thermowell (solid-machined) Models TW15-H, TW15-R and TW15-M

WIKA data sheet TW 95.15

Applications

- Chemical industry, process technology, apparatus construction
- For high chemical demands
- For high process loads

Special features

- International standard
- Model TW15-R: Design suitable for use of special material
- Possible thermowell forms:
 - tapered, straight or stepped
 - "Quill Tip" version (with open tip)



Screw-in thermowell, model TW15-H

Description

Each thermowell is an important component of any temperature measurement point. It is used to separate the process from the surrounding area, thus protecting the environment and operating personnel and keeps aggressive media, high pressures and flow rates from the temperature sensor itself and thereby enables the thermometer to be exchanged during operation.

Based on the almost limitless application possibilities, there are a large number of variants, such as thermowell designs or materials. The type of process connection and the basic method of manufacture are important design differentiation criteria. A basic differentiation can be made between threaded and weld-in thermowells, and those with flange connections.

Furthermore, one can differentiate between fabricated and solid-machined thermowells. Fabricated thermowells are constructed from a tube, that is closed at the tip by a welded solid tip. Solid-machined thermowells are manufactured from barstock.

The TW15 series of solid-machined screw-in thermowells are suitable for use with numerous electrical and mechanical thermometers from WIKA.

Due to the heavy-duty design, these international design thermowells are the first choice for use the chemical and petrochemical industries and in plant construction.

Standard version

Versions

Model TW15-H: hexagon (continuous)
 Model TW15-R: wrench flats
 Model TW15-M: round with hexagon

Thermowell materials

Stainless steel 304/304L, 316/316L, A105, 1.4571,
 Hastelloy C4 (2.4610), Hastelloy C276 (2.4819),
 Monel 400 (2.4360), titanium grade 2 (3.7035)
 Materials per ASTM specifications

Process connection

Male thread ½ NPT, ¾ NPT, 1 NPT

Connection to thermometer

G ½, ½ NPT (female)
 "Quill Tip" version with weld-in connection ½" and ¾"

Bore size

Ø 6.6 mm, Ø 8.5 mm

Insertion length U

To customer specification

Connection length H

To customer specification (min. 45 mm)

Max. process temperature, process pressure

Depending on

- Thermowell design
 - Dimensions
 - Material
- Process conditions
 - Flow rate
 - Density of medium

Options

- Other dimensions and materials
- "Quill Tip" version
- Quality certificates
- Thermowell calculation to ASME PTC 19.3 TW-2010 is recommended in critical applications as a WIKA engineering service

For further information see Technical information IN 00.15 "Strength calculation for thermowells".

Dimensions in mm

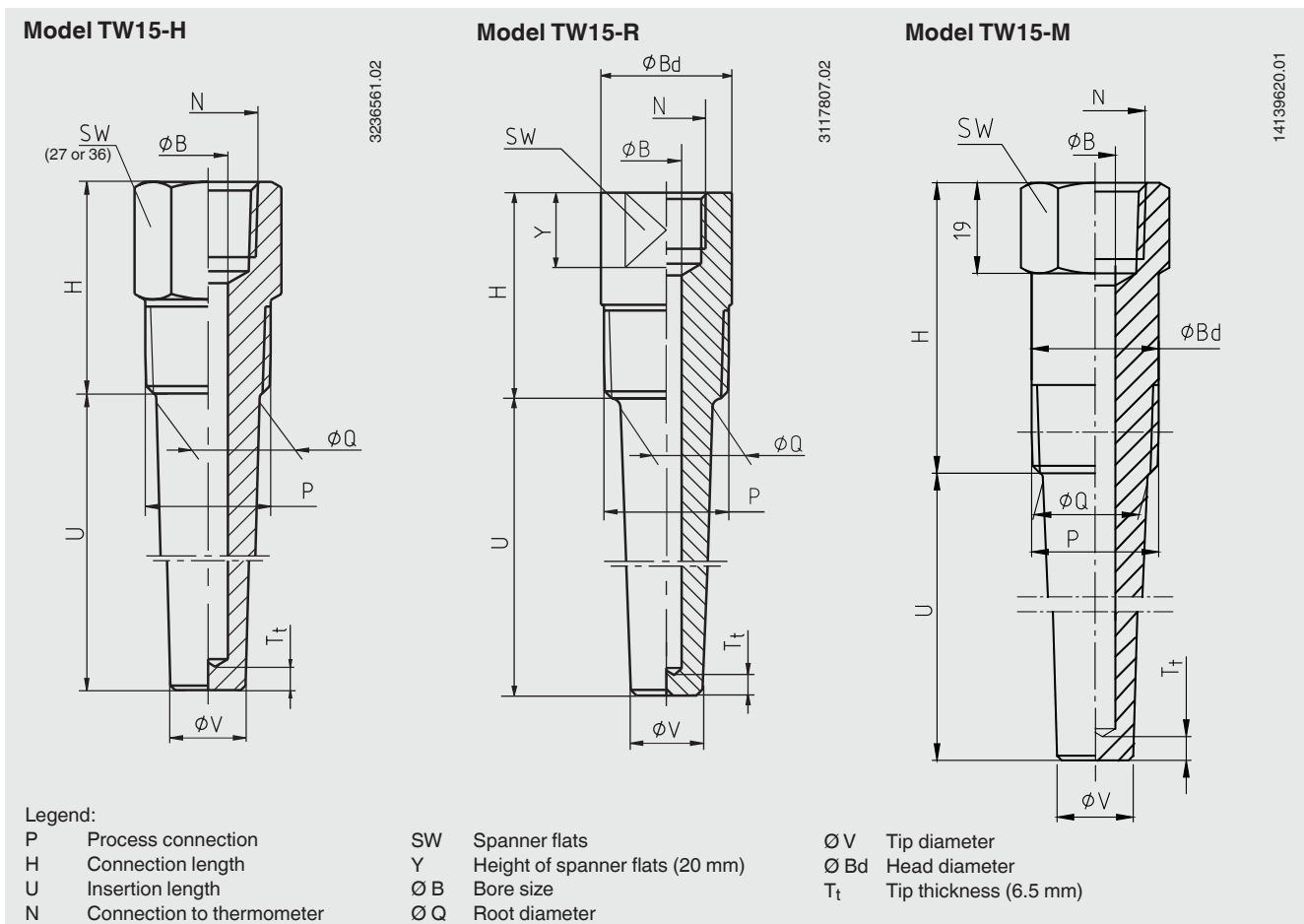

“Quill Tip” version

Standard

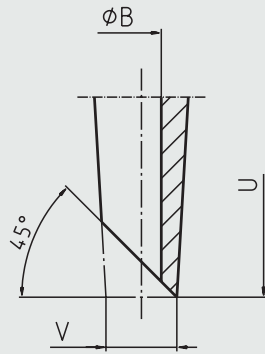

Option: straight

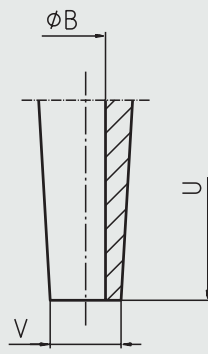

11536128.01

Thermowell form tapered

Dimensions in mm						Weight in kg	
P	N	ϕQ	ϕV	ϕB	H	U = 2 1/2"	U = 7 1/2"
1/2 NPT	1/2 NPT or G 1/2	16	13	6.6 or 8.5	45	0.20	0.36
3/4 NPT	1/2 NPT or G 1/2	22	16	6.6 or 8.5	45	0.31	0.56
1 NPT	1/2 NPT or G 1/2	27	19	6.6 or 8.5	45	0.50	0.84

Suitable stem lengths of mechanical dial thermometers

Connection type	Stem length l_1
S, 4, 5	$l_1 = U + H - 10 \text{ mm}$
2	$l_1 = U + H - 30 \text{ mm}$

Ordering information

Model / Thermowell form / Process connection / Connection to thermometer / Insertion length U / Connection length H / Thermowell material / Head diameter ϕB_d / Bore diameter ϕB / Root diameter ϕQ / Tip diameter ϕV / Assembly with thermometer / Certificates / Options

© 2007 WIKA Alexander Wiegand SE & Co. KG, all rights reserved.
The specifications given in this document represent the state of engineering at the time of publishing.
We reserve the right to make modifications to the specifications and materials.

