

Thermowell with flange (solid-machined)

Wetted parts special material, with washer disc

Model TW10-P

WIKA data sheet TW 95.12

Applications

- Chemical industry, process technology, apparatus construction
- For high chemical demands
- For high process loads

Special features

- Good price/performance ratio
- Wetted parts made of special material
- Non-wetted flange from 316/316L stainless steel
- Thermowell welded to one unit
- Possible thermowell forms:
 - tapered, straight or stepped
 - "Quill Tip" version (with open tip)



Thermowell with flange, model TW10-P

Description

Each thermowell is an important component of any temperature measurement point. It is used to separate the process from the surrounding area, thus protecting the environment and operating personnel and keeps aggressive media, high pressures and flow rates from the temperature sensor itself and thereby enables the thermometer to be exchanged during operation.

Based on the almost limitless application possibilities, there are a large number of variants, such as thermowell designs or materials. The type of process connection and the basic method of manufacture are important design differentiation criteria. A basic differentiation can be made between threaded and weld-in thermowells, and those with flange connections.

Furthermore, one can differentiate between fabricated and solid-machined thermowells. Fabricated thermowells are constructed from a tube, that is closed at the tip by a welded solid tip. Solid-machined thermowells are manufactured from barstock.

The TW10 series of solid-machined thermowells with flange connection are suitable for use with numerous electrical and mechanical thermometers from WIKA.

Due to the heavy-duty design in conjunction with highly corrosion resistant materials, these thermowells are the first choice for use the chemical and petrochemical industries and in plant construction.

Standard version

Thermowell materials

Hastelloy C4 (2.4610), Hastelloy C276 (2.4819),
Monel 400 (2.4360), titanium grade 2 (3.7035) ¹⁾

Flange

Per ASME, EN 1092-1, DIN 2527

Connection to thermometer

½ NPT, G ½ female

"Quill Tip" version with weld-in connection ½" and ¾"

Bore size

Ø 6.6 mm, Ø 8.5 mm

Insertion length U

To customer specification

Connection length H

57 mm, 83 mm (standard)

Others on request

Max. process temperature, process pressure

Depending on

- Thermowell design
 - Dimensions
 - Material
 - Flange pressure rating
- Process conditions
 - Flow rate
 - Density of medium

1) For titanium grade 2 (3.7035) material, the flange is designed to be a removable slip-on flange

Options

- Other dimensions and materials
- "Quill Tip" version
- Certificates
- Thermowell calculation to ASME PTC 19.3-2010 is recommended in critical applications as a WIKA engineering service

For further information see Technical Information IN 00.15 "Strength calculation for thermowells".

Dimensions in mm

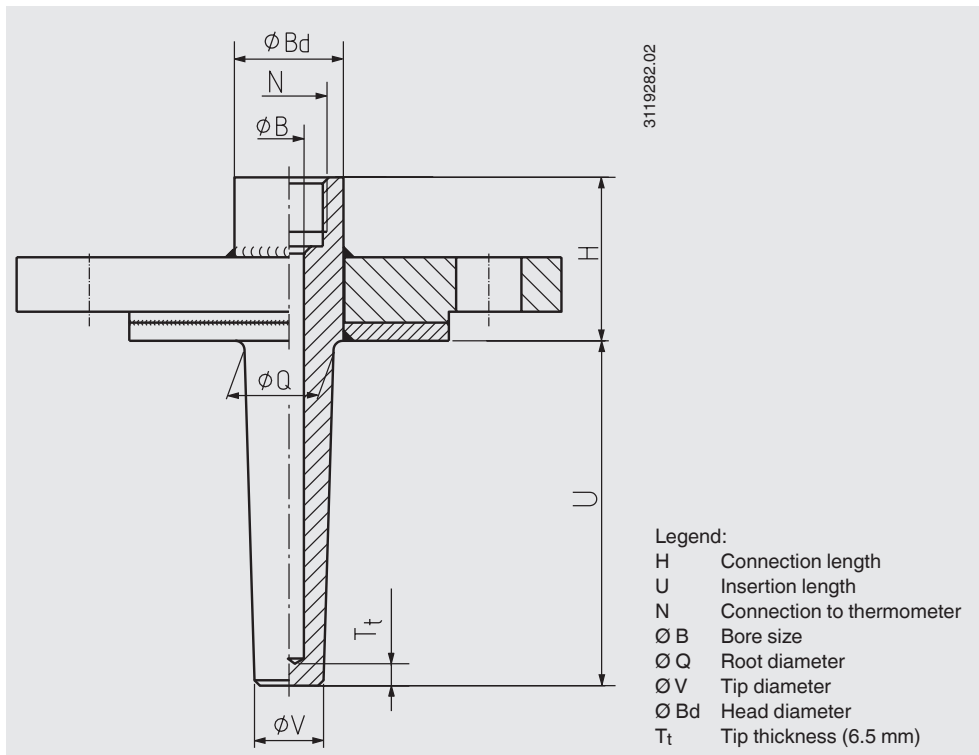

"Quill Tip" version

Standard

Option: straight

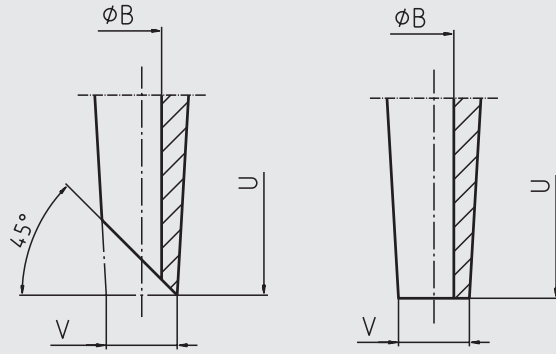

ASME flange, model TW10-P-A

DN	PN in lbs	Dimensions in mm					Weight in kg		
		H	Ø Q	Ø V	Ø B	Ø Bd	U = 4"	U = 13"	U = 22"
1"	150	2 ¼" (approx. 57 mm)	22	16	6.6 or 8.5	30	1.6	2.1	2.5
	300	2 ¼" (approx. 57 mm)	22	16	6.6 or 8.5	30	2.3	2.8	3.2
	600	2 ¼" (approx. 57 mm)	22	16	6.6 or 8.5	30	2.5	3.0	3.4
	1,500	3 ¼" (approx. 83 mm)	22	16	6.6 or 8.5	30	4.7	5.2	5.6
1½"	150	2 ¼" (approx. 57 mm)	25	19	6.6 or 8.5	30	2.0	2.6	3.2
	300	2 ¼" (approx. 57 mm)	25	19	6.6 or 8.5	30	3.5	4.1	4.7
	600	2 ¼" (approx. 57 mm)	25	19	6.6 or 8.5	30	4.2	4.9	5.5
	1,500	3 ¼" (approx. 83 mm)	25	19	6.6 or 8.5	30	6.9	7.6	8.2
2"	150	2 ¼" (approx. 57 mm)	25	19	6.6 or 8.5	30	2.8	3.4	4.0
	300	2 ¼" (approx. 57 mm)	25	19	6.6 or 8.5	30	4.0	4.6	5.2
	600	2 ¼" (approx. 57 mm)	25	19	6.6 or 8.5	30	4.5	5.2	5.8
	1,500	3 ¼" (approx. 83 mm)	25	19	6.6 or 8.5	30	11.7	12.3	13.0

EN, DIN flanges, model TW10-P-A

DN	PN in lbs	Dimensions in mm					Weight in kg	
		H	Ø Q	Ø V	Ø B	Ø Bd	U = 160 mm	U = 500 mm
25	40	45	22	16	6.2 or 10.2	30	1.94	2.62
	63/64	45	22	16	6.2 or 10.2	30	3.24	3.92
	100	45	22	16	6.2 or 10.2	30	3.24	3.92
40	40	45	25	19	6.2 or 10.2	30	3.06	4.00
	63/64	45	25	19	6.2 or 10.2	30	4.76	5.70
	100	45	25	19	6.2 or 10.2	30	4.76	5.70
50	40	45	25	19	6.2 or 10.2	30	3.86	4.80
	63/64	45	25	19	6.2 or 10.2	30	5.16	6.10
	100	45	25	19	6.2 or 10.2	30	6.56	7.50
80	40	60	25	19	6.2 or 10.2	30	6.56	7.50
	63/64	60	25	19	6.2 or 10.2	30	7.56	8.50
	100	60	25	19	6.2 or 10.2	30	10.16	11.10
100	40	60	25	19	6.2 or 10.2	30	8.26	9.20
	63/64	60	25	19	6.2 or 10.2	30	10.86	11.80
	100	60	25	19	6.2 or 10.2	30	14.96	15.90

Suitable stem lengths of mechanical dial thermometers

Connection type	Stem length l ₁
S, 4, 5	l ₁ = U + H - 10 mm
2	l ₁ = U + H - 30 mm

Sealing face roughness

Flange standard		AARH in μinch	Ra in μm	Rz in μm
ASME B16.5	Stock finish	125 ... 250	3.2 ... 6.3	-
	Smooth finish	< 125	< 3.2	-
EN 1092-1	Form B1	-	3.2 ... 12.5	12.5 ... 50
	Form B2	-	0.8 ... 3.2	3.2 ... 12.5
DIN 2527	Form C	-	-	40 ... 160
	Form E	-	-	< 16

Ordering information

Model / Thermowell form / Nominal diameter DN / Pressure rating PN / Sealing face / Connection to thermometer / Wall thickness of flange nozzle / Insertion length U / Connection length H / Flange material / Thermowell material / Head diameter / Bore diameter \varnothing B / Root diameter \varnothing Q / Tip diameter \varnothing V / Assembly with thermometer / Certificates / Options

© 2007 WIKA Alexander Wiegand SE & Co. KG, all rights reserved.
The specifications given in this document represent the state of engineering at the time of publishing.
We reserve the right to make modifications to the specifications and materials.



WIKAL Alexander Wiegand SE & Co. KG
Alexander-Wiegand-Straße 30
63911 Klingenberg/Germany
Tel. (+49) 9372/132-0
Fax (+49) 9372/132-406
E-mail info@wika.de
www.wika.de