

# Differential pressure gauge with capsule element Model 716.11, measuring system copper alloy Model 736.11, measuring system stainless steel

WIKA data sheet PM 07.07



for further approvals  
see page 2

## Applications

- Differential pressure measurement at measuring points with very low differential pressures, for gaseous, dry, clean, oil and grease free media
- Model 736.11 also for aggressive media and environment
- Filter monitoring in ventilation and heating systems
- Filter monitoring in overpressure and clean rooms
- Differential pressure controlled monitoring of ventilator and blast pressures

## Special features

- Differential pressure measuring ranges from 0 ... 2.5 mbar
- As a standard zero adjustment in front
- Ingress protection IP 66
- Case from stainless steel

## Description

### Design

For very low differential pressures, DT - GM 87 10 226

### Nominal size in mm

Model 716.11: NS 63, 100, 160

Model 736.11: NS 100, 160

### Accuracy class

1.6

### Scale ranges

Model 716.11: NS 63: 0 ... 16 to 0 ... 400 mbar

NS 100: 0 ... 10 to 0 ... 250 mbar

NS 160: 0 ... 6 to 0 ... 250 mbar

Model 736.11: NS 100: 0 ... 16 to 0 ... 250 mbar

NS 160: 0 ... 2.5 to 0 ... 250 mbar

or all other equivalent vacuum or combined pressure and vacuum ranges

### Pressure limitation

Steady: Full scale value

Fluctuating: 0.9 x full scale value



Differential pressure gauge model 716.11

### Overpressure safety

Full scale value

### Max. working pressure (static pressure)

NS 63: 400 mbar

NS 100, 160: 250 mbar

### Permissible temperature

Ambient: -20 ... +60 °C

Medium: +70 °C maximum

### Temperature effect

When the temperature of the measuring system deviates from the reference temperature (+20 °C):

max.  $\pm 0.5$  %/10 K of full scale value

### Ingress protection

IP 66 per EN 60529 / IEC 60529

## Design and operating principle

- Pressure retaining case with capsule measuring element,  
⊕ pressure is retained in capsule element  
⊖ pressure is retained in case
- Pressure differential between ⊕ and ⊖ side deflects the capsule element
- The deflection is transmitted to the movement and indicated

Mounting according to affixed symbols,  
⊕ high pressure and ⊖ low pressure

### Mounting by means of:

- Rigid measuring lines
- Panel or surface mounting flange (option)
- Mounting bracket for wall or pipe mounting (option)

## Standard version

### Process connection (wetted)

Model 716.11: Copper alloy

Model 736.11: Stainless steel

Lower mount (LM), parallel one behind the other

NS 63: 2 x G 1/8 B (male), 14 mm flats

NS 100, 160: 2 x G 1/2 B (male), 22 mm flats

### Pressure element (wetted)

Model 716.11: Copper alloy

Model 736.11: Stainless steel

### Movement (wetted)

Model 716.11: Copper alloy

Model 736.11: Stainless steel

### Dial (wetted)

Aluminium, white, black lettering

### Pointer (wetted)

Aluminium, black

### Zero adjustment (wetted)

Adjusting device for screwdriver in front

### Case (wetted)

Stainless steel, pressure retaining,

NS 100, 160: With blow-out device PUR

### Window (wetted)

Clear non-splintering plastic

### Sealings (wetted)

NBR, silicone

### Bezel ring

Cam ring (bayonet type), stainless steel

## Options

- Other process connection
- Sealings (model 910.17, see data sheet AC 09.08)
- Panel or surface mounting flange
- Mounting bracket for wall or pipe mounting (data sheet AC 09.07)
- Pressure compensating valve (data sheet AC 09.11) - wetted
- Back mount (BM)
- Overpressure safety  
⊕ side with scale ranges  
0 ... 2.5 mbar to 0 ... 25 mbar: 3 x full scale value  
≥ 0 ... 40 mbar: To maximum working pressure  
⊖ side: On request

## Approvals

- **GOST**, metrology/measurement technology, Russia
- **GOST-R**, import certificate, Russia
- **CRN**, safety (e.g. electr. safety, overpressure, ...), Canada

## Certificates <sup>1)</sup>

- 2.2 test report per EN 10204 (e.g. state-of-the-art manufacturing, material proof, indication accuracy)
- 3.1 inspection certificate per EN 10204 (e.g. indication accuracy)

1) Option

Approvals and certificates, see website

# Dimensions in mm

## Standard version

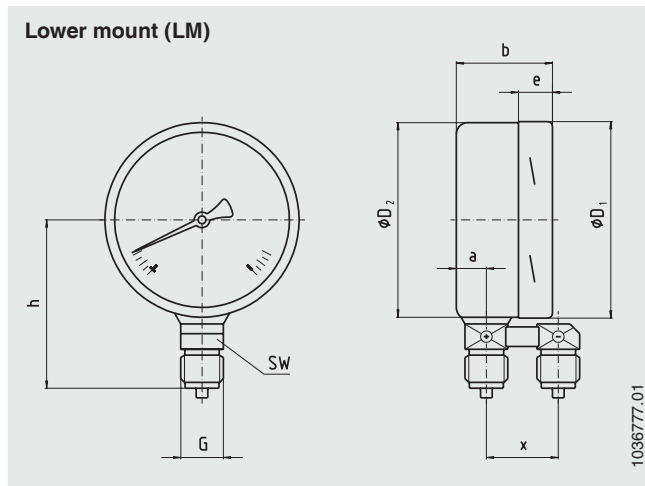

## Option

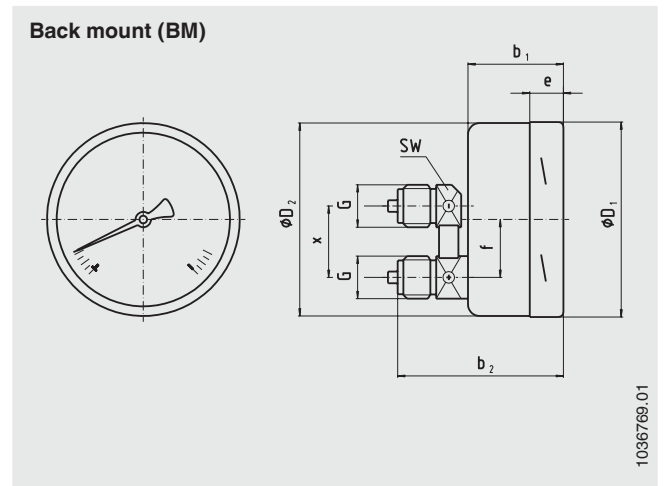

NS	Dimensions in mm												Weight in kg
	a	b	b <sub>1</sub>	b <sub>2</sub>	D1	D <sub>2</sub>	e	f	G	h ±1	X	SW	
63	11	48.5	38	55	64	62	13.5	20	2 x G 1/8 B <sup>1)</sup>	49	23	14	0.23
100	15.5	48.5	49.5	84	101	99	17.5	30	2 x G 1/2 B	87	37	22	0.73
160	15.5	48.5	51.5	87	161	159	17.5	50	2 x G 1/2 B	118	37	22	1.33

Process connection per EN 837-3 / 7.3

1) Without spigot

## Ordering information

Model / Nominal size / Scale range / Max. working pressure (static pressure) ... mbar / Connection size / Connection location / Options

© 2008 WIKA Alexander Wiegand SE & Co. KG, all rights reserved.  
The specifications given in this document represent the state of engineering at the time of publishing.  
We reserve the right to make modifications to the specifications and materials.

